

(No Model.)

3 Sheets—Sheet 1.

J. F. McELROY.  
ELECTRIC SWITCH.

No. 519,338.

Patented May 8, 1894.

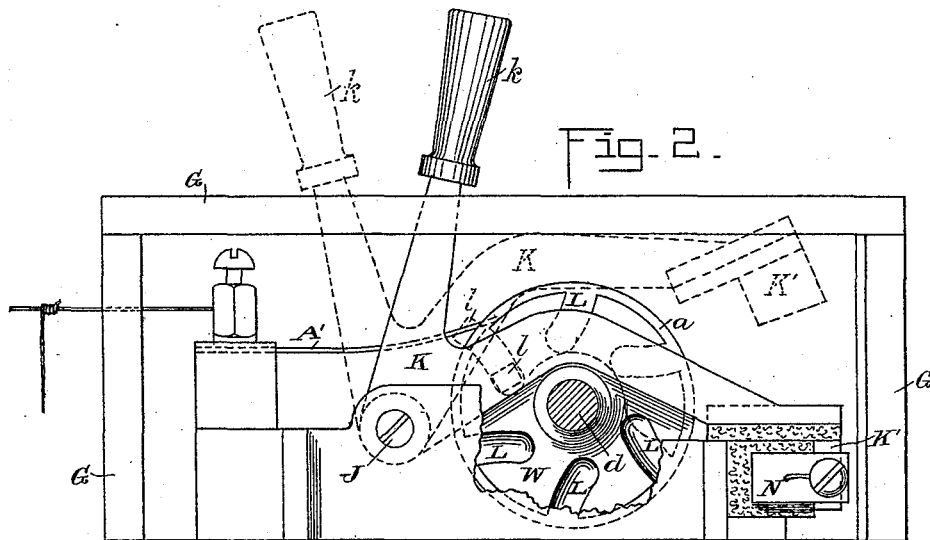
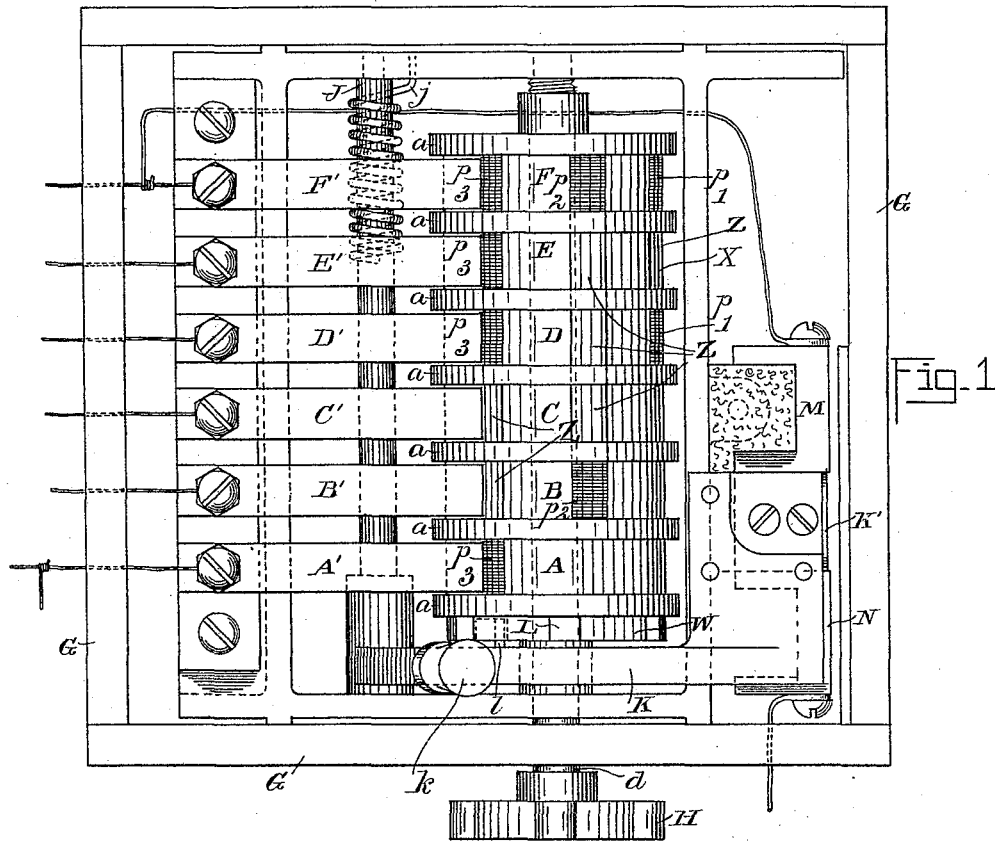

Witnesses:  
*John W. Fisher.*  
*Frederick W. Cameron.*

Inventor,  
*James S. McElroy.*  
*Ward Cameron.*  
 Attorneys

J. F. McELROY.  
ELECTRIC SWITCH.

No. 519,338.

Patented May 8, 1894.

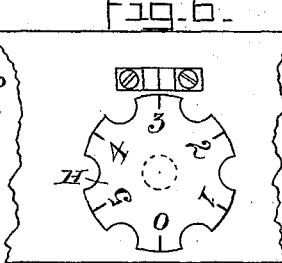
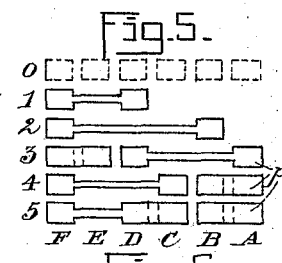
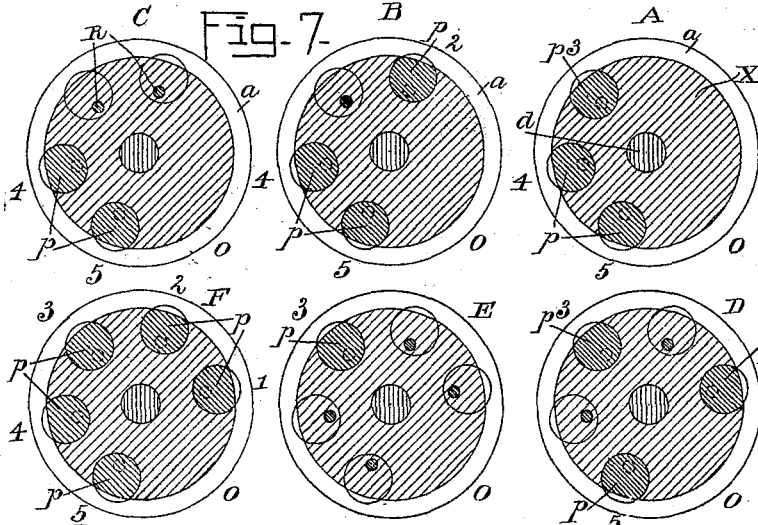
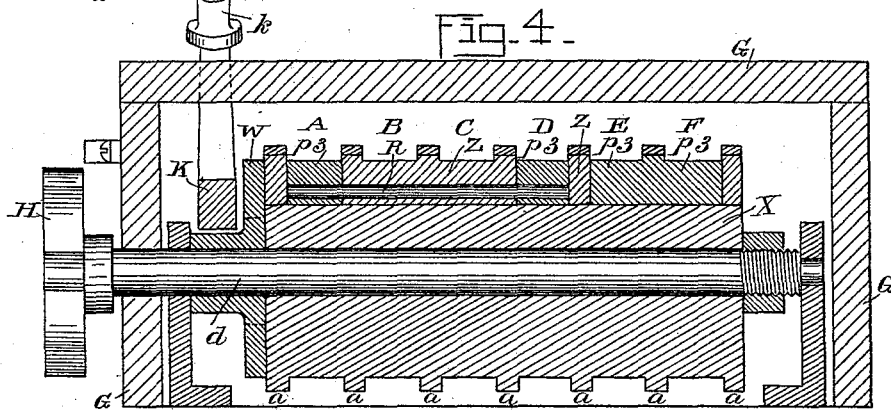
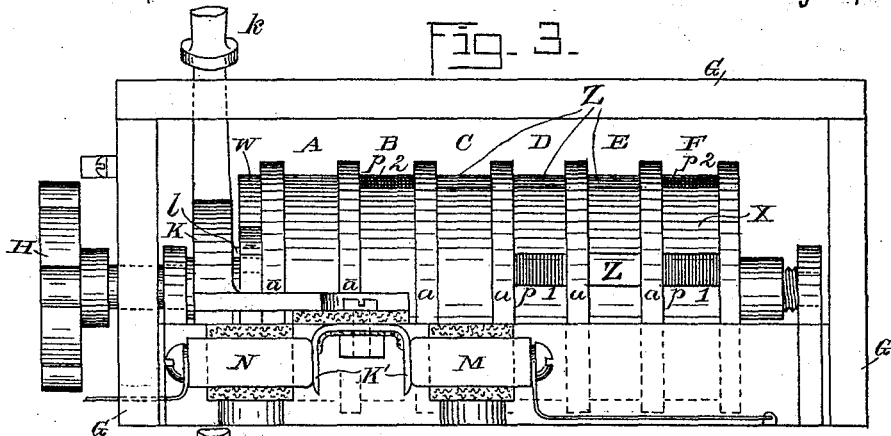

Witnesses =  
*John W. Fisher*  
*Frederick W. Cameron.*

Inventor:  
*James F. McElroy.*  
*Ward & Cameron*  
 Attorneys

(No Model.)

3 Sheets—Sheet 3.

J. F. McELROY.  
ELECTRIC SWITCH.

No. 519,338.

Patented May 8, 1894.

FIG. 8.

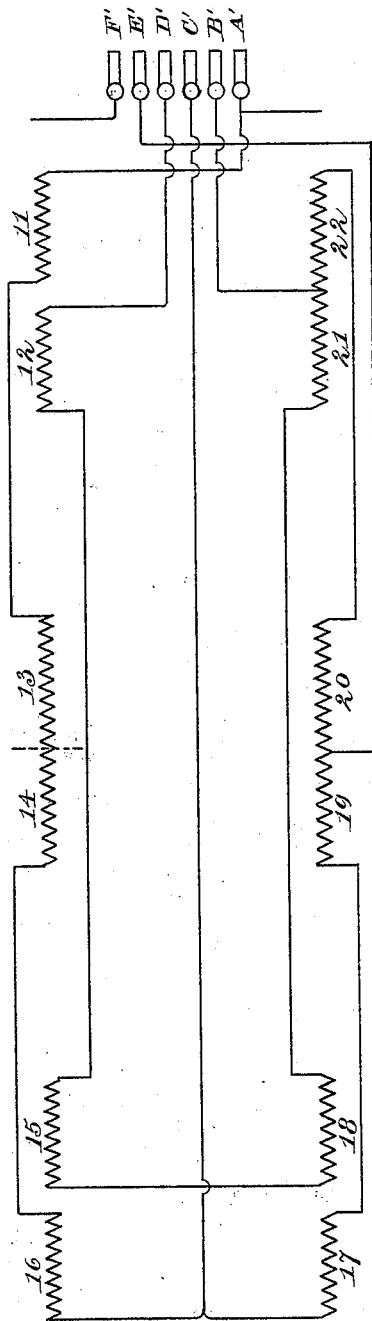

Witnesses:  
*John W. Fisher.*  
*Frederick W. Cameron.*

Inventor,  
*James F. McElroy.*  
by *Ward & Cameron.*  
Attorneys.

# UNITED STATES PATENT OFFICE.

JAMES F. MCELROY, OF ALBANY, NEW YORK, ASSIGNOR TO THE CONSOLIDATED CAR-HEATING COMPANY, OF WHEELING, WEST VIRGINIA.

## ELECTRIC SWITCH.

SPECIFICATION forming part of Letters Patent No. 519,338, dated May 8, 1894.

Application filed August 2, 1893. Serial No. 482,180. (No model.)

*To all whom it may concern:*

Be it known that I, JAMES F. MCELROY, a citizen of the United States, residing in the city and county of Albany, State of New York, have invented a new and useful Electric Switch, of which the following is a specification.

My invention relates to improvements in mechanism for directing the current of electricity; and the object of my invention is to provide an electric switch particularly adapted for use in mechanism for heating with electricity. I accomplish this object by means of the mechanism illustrated in the accompanying drawings, in which—

Figure 1 is a plan. Fig. 2 is an end elevation. Fig. 3 is a side elevation. Fig. 4 is a longitudinal section. Fig. 5 is a detail view showing the connections between the metallic plugs in the cylinder. Fig. 6 is an end elevation of the knob H. Fig. 7 is a series of cross sections of the cylinder showing the position of the metallic plugs therein, and Fig. 8 is a view of the wiring in the car.

Similar letters and figures refer to similar parts throughout the several views.

The cylinder X is composed of any suitable material and mounted upon a spindle *d* journaled within the box G and has keyed to it at one end the knob H. At one end of the cylinder and secured thereto, I arrange the notched wheel W. Before mounting the cylinder, I core out a series of passage ways extending in a path parallel to its axis; said passage ways usually extending from one end of the cylinder to the other. Within the passage ways thus cored out of the cylinder, I place a series of metallic plugs *p* separated by an insulating substance Z; said plugs sometimes connected by metallic rods R in the manner hereinafter described. After placing the plugs *p* and the insulating substance Z in position, I put the cylinder upon a lathe and cut down the surface of the cylinder immediately above the plugs placed within the cylinder forming a series of annular depressions, A, B, C, D, E and F extending around the cylinder, until the metallic plugs are flush with the periphery, making thus a series of narrow partitions *a* between the annular depressions A, B, C, D, E and F.

I arrange the metallic plugs *p* as shown in Figs. 1, 3, and 4. Thus in section A there are three plugs, (see Fig. 7) section B also contains three plugs; section C two, section D 55 three; section E one and section F five. By referring to Fig. 5 the letters at the bottom of the figure refer to the sections and show by the number of squares in the upright column in full lines, the number of metallic plugs in 60 each section. The figures at the right of Fig. 5 refer to the various series of metallic plugs in the section and show how they are connected.

I have indicated on Figs. 1, 3, 4 and 7 the 65 positions of the various plugs and numbered them according to which series they belong. Thus in Fig. 1 at the top of the cylinder, is seen series 1; lower down is series 2, while the springs are in contact with series 3. Fig. 4 70 shows the connection of the plugs of the third series, in which the plug in section A is connected with the plug in section D by means of the rod R separated by the insulating material Z. The plug in section E extends 75 through into section F.

Within the box G, I mount the rocking shaft J carrying a spiral spring *j* and having pivoted to it the bell-crank lever K. One end of the lever K is provided with a handle *k*; 80 the opposite end carries the metallic disk K'. One side of the arm of the lever which carries the disk K' is provided with a stud *l* constructed to engage with the openings L in the wheel W when the disk K' is between the 85 posts M and N. The disk K' is constructed to fit snugly between the metallic posts M and N; the posts M and N are insulated from the box and cylinder, as is also the disk K' from the lever K. The post N is connected by wire 90 to one pole of the battery; the post M is connected by wire to an electric finger F'; said electric finger F' being attached to an insulated bolt in the frame of the box at one end, its other end being in contact with section F 95 of the cylinder. In a similar way the fingers E', D', C', B', and A' are arranged in contact with the corresponding sections of the cylinder. Thus in Fig. 4 the current passes from the battery to the post N through 100 disk K' to the post M and is carried to finger F' (see Fig. 1) thence to the plug in sec-

tions E and F, thence through finger E' to the resistance to be heated and returns to the finger E' and plug in section D and is conducted to the plug in section A from thence  
5 it passes to the ground.

By the operation of the bell-crank lever K, the circuit is made or broken. When the circuit is complete, the disk K' being in position between the posts M and N, the cylinder  
10 is locked, the lug I within the wheel W prevents the oscillation of the cylinder, and in order to change the position of the cylinder and thereby operate the switch, it is necessary to first break the circuit by operating  
15 the lever. The numbers on the knob H shown in Fig. 6, indicate the position of the cylinder and after the lever is drawn back, the cylinder may be revolved by means of the knob to the position indicated by the figures and then  
20 the circuit may be made and the switch placed in operation. By this construction of the switch and locking device, I prevent sparking at the spring contact with the cylinder, which would take place if the circuit were  
25 made when the cylinder was revolved, and I make and break the circuit at a point above the cylinder, which is controlled by the lever. It will be noticed that the lever performs a double function, first that of breaking the  
30 circuit, and second that of locking the rotary cylinder in position, so that it cannot be turned until after the circuit is broken. It moreover makes it impossible to close the circuit through the switch when the cylinder is  
35 not in its proper position.

I describe one adaptation of my switch, that connected with heating by electricity. The heaters in the car are numbered 11, 12, 13, 14, 15, 16, 17, 18, 19, 20, 21, and 22, all connected together and placed two at each end  
40 and two in the center of each side of the car; the finger A' being connected with heater 11; B' with heaters 21 and 22; C' with heaters 16 and 17; D' with heater 12; E' with heaters 19 and 20. By this arrangement of the heaters and their connections when the fingers D' and F' are in contact with the plugs in disks D and F, as shown on series 1, the current passes  
45 first to heater 12, then to heaters 15, 18, 21, 22, 20, 19, 17, 16, 14, 13 and 11 and through the ground wire at A' out, having twelve heaters in the series. When the second series is in connection, the current passes from finger B' to heaters 22, 20, 19, 17, 16, 14, 13 and 11, having eight heaters in series. When the third series is in connection, the current passes from finger E' to heaters 19, 17, 16, 14, 13 and 11 and heaters 20, 22, 21, 18, 15 and 12, making two series of six heaters each. When the  
60 fourth series is in connection, the current passes from the finger C' to heaters 16, 14, 13 and 11 and heaters 17, 19, 20 and 22, making two series of four heaters each. When the fifth series is in connection, the current passes  
65 from finger D' to heaters 12, 15, 18 and 21 and from finger C' to heaters 16, 14, 13 and 11 and 17, 19, 20 and 22, making three series of four

heaters each. In the first position all of the heating surface within the car is placed in series. In the second position two-thirds are  
70 placed in series. In the third position, the total heating surface is divided into two equal parts, and these parts are placed in multiple with reference to each other. In the fourth position, two-thirds of the heating surface is  
75 divided into two equal parts and these parts are placed in multiple with reference to each other. In the fifth position, the total heating surface is divided into three equal parts and these parts are placed in multiple with refer-  
80 ence to each other.

In heating up a car, I preferably place the switch in the fifth position, allowing a large current to flow through the heater, hence I obtain a rapid heating of the car. As the car  
85 becomes warm ready to go on the road, I then turn the switch in one of the other positions requiring less current; the position of the switch depending upon the temperature of the outside air. As the flow of current com-  
90 mences, the heating effect may be varied in this manner. Thus I am enabled to set the switch so as to give just the heat required to make a car comfortable in any weather.

What I claim as my invention, and desire  
95 to secure by Letters Patent, is—

1. In an electric switch, a cylinder provided with a series of passage ways cored therefrom and extending in a path parallel to its axis, a series of metallic plugs placed within said  
100 passage ways, insulating material placed between said metallic plugs, the periphery of the cylinder cut away immediately above each of said plugs, leaving each of said metallic plugs flush with the surface, substantially as  
105 described and for the purpose set forth.

2. In an electric switch, a cylinder provided with a series of passage ways cored therefrom and extending in a path parallel to its axis, a series of metallic plugs placed within said  
110 passage ways, insulating material placed between said metallic plugs, the periphery of the cylinder cut away immediately above each of said plugs, leaving each of said metallic plugs flush with the surface, a metallic rod  
115 connecting two or more of said metallic plugs, substantially as described and for the purpose set forth.

3. In an electric switch, a cylinder provided with a series of passage ways cored therefrom  
120 and extending in a path parallel to its axis, a series of metallic plugs placed within said passage ways, insulating material placed between said metallic plugs, with the periphery of the cylinder cut away immediately above  
125 each of said plugs leaving each of said plugs flush with the surface, a spindle upon which said cylinder is mounted, a series of electric fingers in contact with said metallic plugs, each of said fingers attached to a wire carrying the  
130 current of electricity to the switch, one of said fingers attached to a wire connected with the ground, substantially as described and for the purpose set forth.

4. In an electric switch, a cylinder provided with a series of passage ways cored therefrom and extending in a path parallel to its axis, a series of metallic plugs placed within said passage ways, insulating material placed between said metallic plugs, with the periphery of the cylinder cut away immediately above each of said plugs leaving each of said plugs flush with the surface, a series of metallic fingers arranged to come in contact with said metallic plugs in the course of a revolution of the cylinder in such a manner that all the metallic plugs in each series will be in contact with their corresponding fingers simultaneously, substantially as described and for the purpose set forth.

5. In an electric switch, a cylinder provided with a series of passage ways cored therefrom and extending in a path parallel to its axis, a series of metallic plugs placed within said passage ways, insulating material placed between said metallic plugs, with the periphery of the cylinder cut away immediately above each of said plugs leaving each of said plugs flush with the surface, a series of metallic fingers arranged to come in contact with said metallic plugs in the course of a revolution of the cylinder in such a manner that all the metallic plugs in each series will be in contact with their corresponding fingers simultaneously, a spindle upon which said cylinder is mounted, said spindle journaled in a suitable frame, with a knob at the end of said spindle by means of which the cylinder may be rotated, substantially as described and for the purpose set forth.

6. In an electric switch, a cylinder provided with a series of passage ways cored therefrom and extending in a path parallel to its axis, a series of metallic plugs placed within said passage ways, insulating material placed between said metallic plugs, with the periphery of the cylinder cut away immediately above each of said plugs leaving each of said plugs flush with the surface, a series of metallic fingers arranged to come in contact with said metallic plugs in the course of a revolution of the cylinder in such a manner that all the

metallic plugs in each series will be in contact with their corresponding fingers simultaneously, a spindle upon which said cylinder is mounted, said spindle journaled in a suitable frame, with a knob at the end of said spindle by means of which the cylinder may be rotated, a rocking shaft mounted in said frame, a bell crank lever secured to said rocking shaft, a metallic disk on one arm of said bell crank lever adapted to make and break the circuit by entering or leaving the space between the two poles of the switch, substantially as described and for the purpose set forth.

7. In an electric switch, a cylinder provided with a series of passage ways cored therefrom and extending in a path parallel to its axis, a series of metallic plugs placed within said passage ways, insulating material placed between said metallic plugs, with the periphery of the cylinder cut away immediately above each of said plugs leaving each of said plugs flush with the surface, a series of metallic fingers arranged to come in contact with said metallic plugs in the course of a revolution of the cylinder in such a manner that all the metallic plugs in each series will be in contact with their corresponding fingers simultaneously, a spindle upon which said cylinder is mounted, said spindle journaled in a suitable frame, with a knob at the end of said spindle by means of which the cylinder may be rotated, one end of said cylinder provided with a wheel, a notched or corrugated periphery on said wheel, a lever mounted upon a shaft suitably journaled to the frame of the switch, one arm of said shaft provided with a lug fitted to engage in the notches in said wheel by means of which said cylinder may be locked, with a disk at the end of said lever arm adapted to fit between the poles of the switch, substantially as described and for the purpose set forth.

JAMES F. McELROY.

Witnesses:

RALPH W. KIRKHAM,  
MARY AGNES BURKE.